

PITTSBURGH CORNING ACCESSORIES FOR FOAMGLAS® INSULATION SYSTEMS

FOAMGLAS®

Pittsburgh Corning



Pittsburgh Corning has been the leader in cellular glass insulation system technology for more than 75 years. Our FOAMGLAS® Insulation and accessory products provide a comprehensive system solution for most industrial and commercial insulation needs.

The importance of compatible accessory products such as adhesives, coatings, sealants, fabrics and jacketing should not be overlooked. Pittsburgh Corning's accessories are formulated, designed and tested to ensure optimum performance of your FOAMGLAS® insulation system. Without such consideration, the dependability and performance of your system could be at risk. Therefore, we recommend the system approach when specifying insulation and accessory products. This is the most effective way to ensure your insulation system performs now and in the future.

For additional information on FOAMGLAS® insulation, accessories or systems, please contact Pittsburgh Corning at any of our worldwide offices or visit us at www.foamglas.com.

CRYOGENIC/COLD PIPE SYSTEMS

Protective Coating or Protective Jacketing

With Protective Coating and Cladding



Item	Product Name	Product Description	Service Temperature ¹	Supplemental Information
1	Insulation	FOAMGLAS® Insulation	-268°C to 482°C (-450°F to 900°F)	
2	Joint Sealant Options	PITTSEAL® 444Ns Sealant	-150°C to 82°C (-238°F to 180°F)	For joints, protrusions and laps
		PITTSEAL® 444N Sealant	-56.6°C to 82°C (-70°F to 180°F)	For joints, protrusions and laps
3	Vapor Stop	PITTSTOP™ 196 Vapor Stop	-196°C to 121°C (-320°F to 250°F)	
4	Cryogenic Adhesive	PC® 42 Cryogenic adhesive	-196°C to 121°C (-320°F to 250°F)	
5	Bore Coating Options	Hydrocal® B-11 Adhesive	-268°C to 482°C (-450°F to 900°F)	For use on LOX or LIN systems
		PC® 80M Mortar	-196°C to 320°C (-320°F to 608°F)	Meets MIL-I-24244 ASTM C795, NRC 1.36
		HTAA	-268°C to 482°C (-450°F to 900°F)	For use on LOX or LIN systems
		PITTCOTE® 16 LTAA	-182°C to 120°C (-296°F to 248°F)	Not for use on LOX or LIN systems
6	Reinforcing Fabric Options	PC® Fabric 79	No limit listed	
		PC® 150 Mesh	No limit listed	
7	Protective Coating Options	PITTCOTE® 300 Finish	-40°C to 93°C (-40°F to 200°F)	Must be protected from UV exposure with metal or other jacketing
8	Protective Jacketing	PITTCOTE® B100 Jacketing	-50°C to 140°C (-58°F to 284°F)	
		PITTCOTE® IW50 Jacketing	-50°C to 75°C (-4°F to 167°F)	Ideal for asphalt roller coated applications
Other	Strapping Tape Metal Bands Metal Cladding			

¹Service temperature limits are derived from laboratory evaluation of the product. Variations in substrates, loading conditions, or other external factors may further limit service temperature. Always consult Pittsburgh Corning's FOAMGLAS® insulation guide specification for suitability for use recommendations for a specific application.

INDOOR CHILLED WATER PIPE SYSTEMS

For use with Reinforcing Fabric and Protective Coating or Protective Jacketing

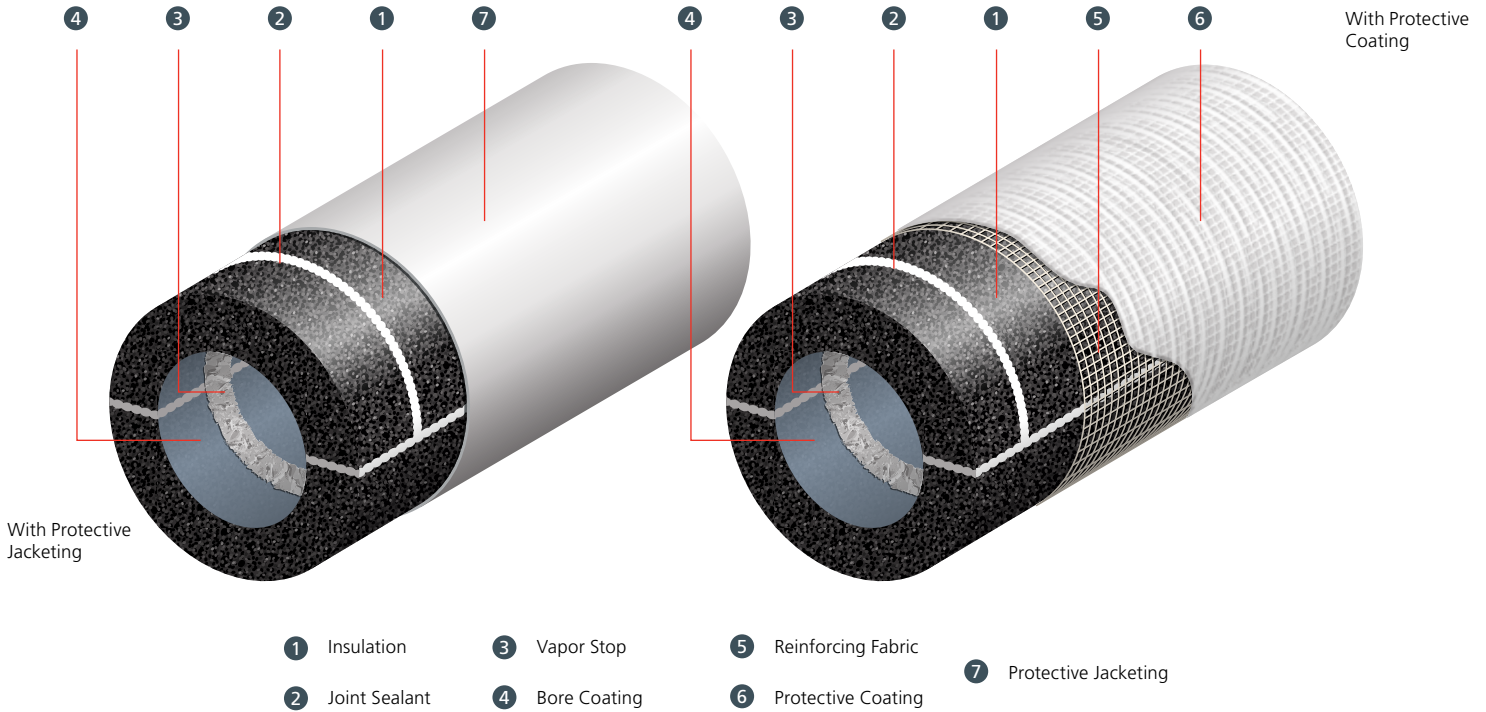

Item	Product Name	Product Description	Service Temperature ¹	Supplemental Information
1 Insulation	FOAMGLAS® Insulation	A lightweight, rigid, cellular glass insulation	-268°C to 482°C (-450°F to 900°F)	
2 Joint Sealant Options	PITTSEAL® 444Ns Sealant	Butyl sealant	-150°C to 82°C (-238°F to 180°F)	For joints, protrusions and laps
	PITTSEAL® 444N Sealant	Butyl sealant	-56.6°C to 82°C (-70°F to 180°F)	For joints, protrusions and laps
	PITTSEAL® CW Sealant	MS polymer	-59°C to 104°C (-75°F to 220°F)	VOC compliant For joints, protrusions and laps
	PC® 18 Bituminous Adhesive	One component bitumen cold glue	-30°C to 80°C (-22°F to 176°F)	
3 Vapor Stop Options	PITTSEAL® 444Ns Sealant	Butyl sealant	-150°C to 82°C (-238°F to 180°F)	For joints, protrusions and laps
	PITTSEAL® 444N Sealant	Butyl sealant	-56.6°C to 82°C (-70°F to 180°F)	For joints, protrusions and laps
	PITTSEAL® CW Sealant	MS polymer	-59°C to 104°C (-75°F to 220°F)	VOC compliant
4 Bore Coating	PITTCOTE® 16 LTAA	A water-based product	-182°C to 120°C (-296°F to 248°F)	
5 Reinforcing Fabric	PC® Fabric 79	Open mesh synthetic fabric	No limit listed	
6 Protective Coating Options	PITTCOTE® 404 Coating	Weather barrier mastic/coating	-34°C to 82°C (-30°F to 180°F)	
7 Protective Jacketing	PITTCOTE® CF Jacketing	Cellulose free fiberglass reinforced vapor retarding jacket	-40°C to 104°C (-40°F to 220°F)	Often supplied pre-jacketed for ease of installation
Other	Metal Cladding Foil Wrap Filament Tape Metal Bands			

¹Service temperature limits are derived from laboratory evaluation of the product. Variations in substrates, loading conditions, or other external factors may further limit service temperature. Always consult Pittsburgh Corning's FOAMGLAS® insulation guide specification for suitability for use recommendations for a specific application.

OUTDOOR CHILLED WATER PIPE SYSTEMS

For use with Reinforcing Fabric and Protective Coating or Protective Jacketing

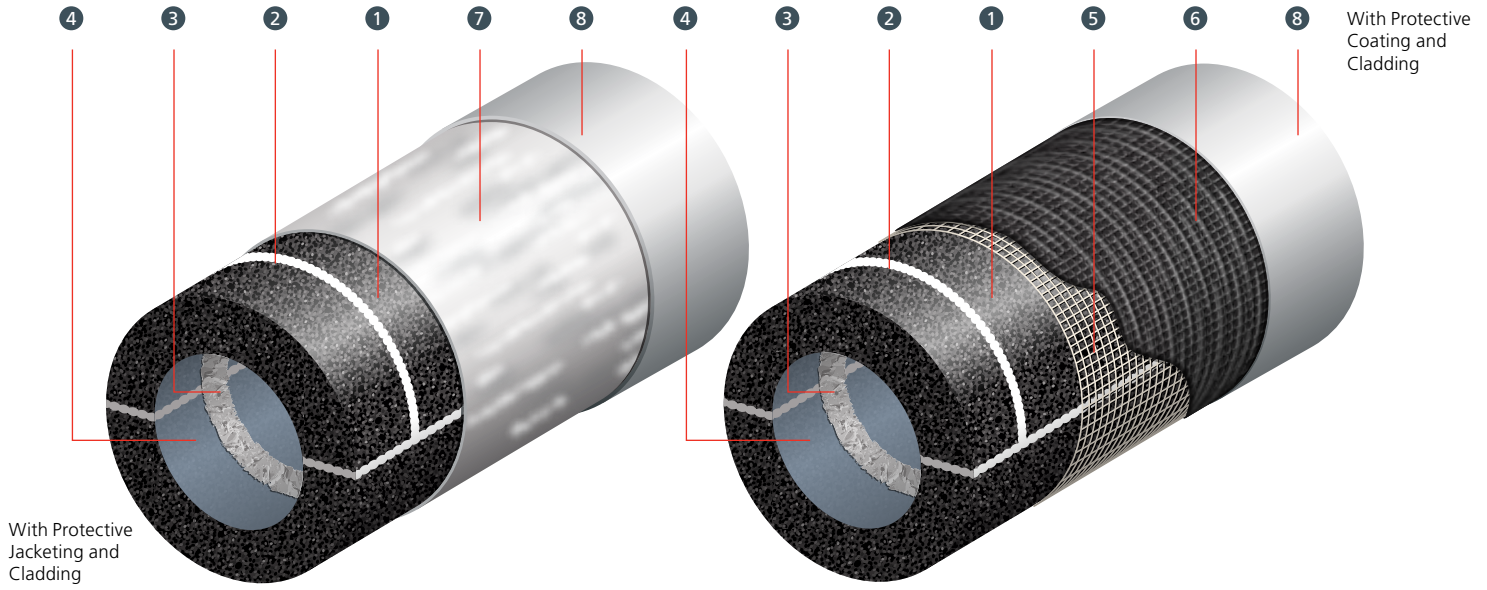

- 1 Insulation
- 2 Joint Sealant
- 3 Vapor Stop
- 4 Bore Coating
- 5 Reinforcing Fabric
- 6 Protective Coating
- 7 Protective Jacketing
- 8 Metal Cladding

Item	Product Name	Product Description	Service Temperature ¹	Supplemental Information
1 Insulation	FOAMGLAS® Insulation	A lightweight, rigid, cellular glass insulation	-268°C to 482°C (-450°F to 900°F)	
2 Joint Sealant Options	PITTSEAL® 444Ns Sealant	Butyl sealant	-150°C to 82°C (-238°F to 180°F)	For joints, protrusions and laps
	PITTSEAL® 444N Sealant	Butyl sealant	-56.6°C to 82°C (-70°F to 180°F)	For joints, protrusions and laps
	PITTSEAL® CW Sealant	MS polymer	-59°C to 104°C (-75°F to 220°F)	VOC compliant For joints, protrusions and laps
3 Vapor Stop	PITTSEAL® 444Ns Sealant	Butyl sealant	-150°C to 82°C (-238°F to 180°F)	
	PITTSEAL® 444N Sealant	Butyl sealant	-56.6°C to 82°C (-70°F to 180°F)	
	PITTSEAL® CW Sealant	MS polymer	-59°C to 104°C (-75°F to 220°F)	
4 Bore Coating	PITTCOTE® 16 LTAA	A water-based product	-182°C to 120°C (-296°F to 248°F)	
5 Reinforcing Fabric	PC® Fabric 79	Open mesh synthetic fabric	No limit listed	
6 Protective Coating Options	PITTCOTE® 300E Coating	Vapor barrier mastic/coating	-40°C to 93°C (-40°F to 200°F)	Must be protected from UV exposure with metal or other jacketing.
7 Protective Jacketing Options	PITTWRAF® B100	Self-sealing aluminum butyl laminate for above-ground systems	-50°C to 140°C (-58°F to 284°F)	
	PITTWRAF® IW50	Self-sealing modified bituminous membrane for above ground systems	-20°C to 75°C (-4°F to 167°F)	Ideal for asphalt roller coated applications
	PITTWRAF® IW30	Self-sealing modified bituminous membrane for above ground systems	-32°C to 38°C (-25°F to 100°F)	
Other	Metal Cladding Filament Tape Metal Bands			

¹Service temperature limits are derived from laboratory evaluation of the product. Variations in substrates, loading conditions, or other external factors may further limit service temperature. Always consult Pittsburgh Corning's FOAMGLAS® insulation guide specification for suitability for use recommendations for a specific application.

ABOVE AMBIENT/HIGH TEMPERATURE PIPE SYSTEMS

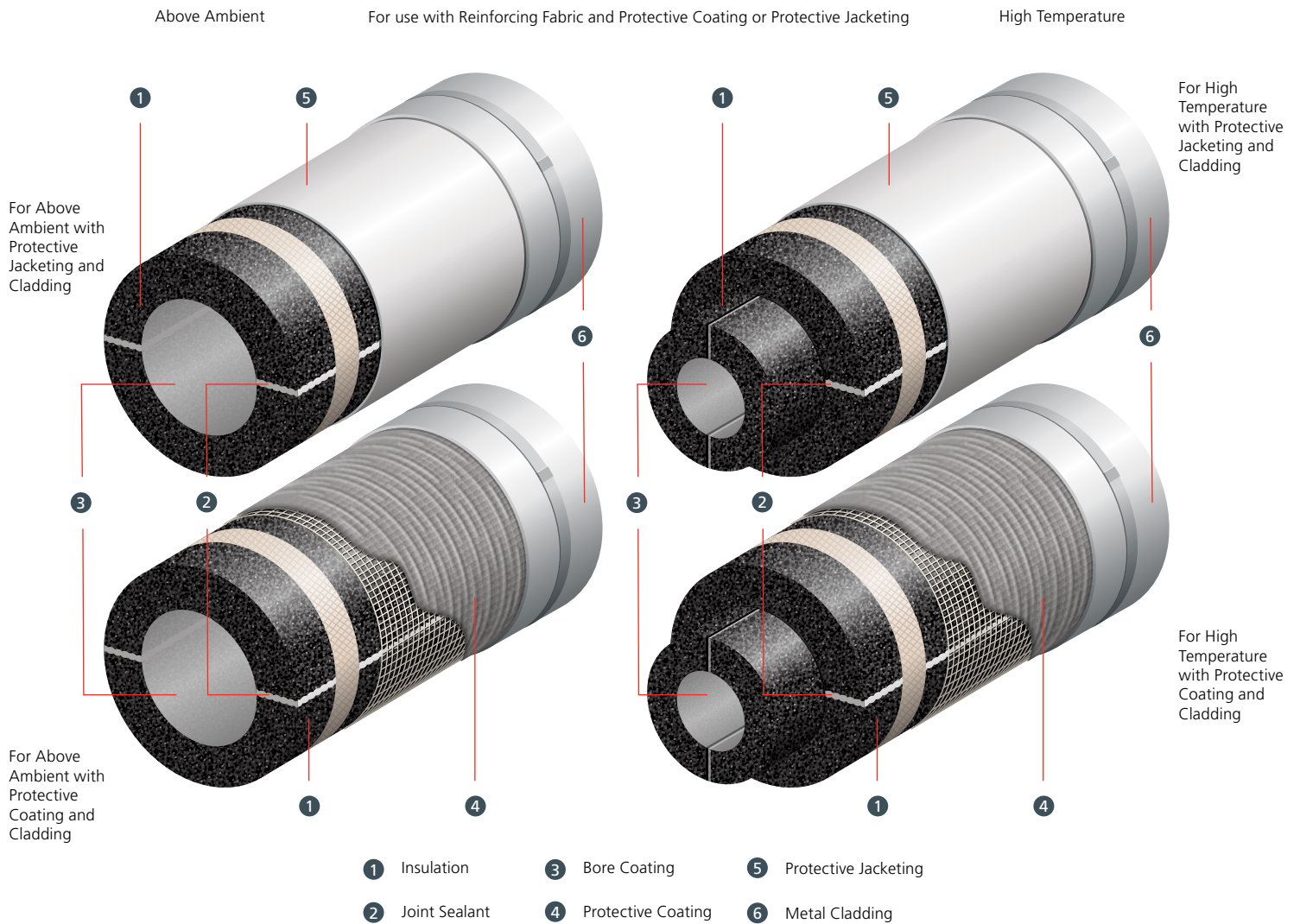

Item	Product Name	Product Description	Service Temperature ¹	Supplemental Information
1 Insulation Options	FOAMGLAS® Insulation	A lightweight, rigid, cellular glass insulation	-268°C to 482°C (-450°F to 900°F)	
	FOAMGLAS® Stratafab™ Insulation		-268°C to 482°C (-450°F to 900°F)	Not for indoor use
2 Sealant Options	PITTSEAL® 444Ns Sealant	Butyl sealant	-150°C to 82°C (-238°F to 180°F)	For joints, protrusions and laps
	PITTSEAL® 444N Sealant	Butyl sealant	-56.6°C to 82°C (-70°F to 180°F)	For joints, protrusions and laps
	PC® RTV 450 Sealant	High Temperature Silicone Sealant	-100°C to 204°C (-248°F to 400°F)	For joints, protrusions and laps
	PC® Hi-Temp RTV Sealant	High Temperature Silicone Sealant	-150°C to 260°C (-238°F to 500°F)	For joints, protrusions and laps
3 Bore Coating	Hydrocal B-11 Adhesive	A reactive gypsum product	-268°C to 482°C (-450°F to 900°F)	
	PC® 80M, Mortar	Two component, inorganic noncombustible bore coating	-196°C to 320°C (-320°F to 608°F)	Stainless Steel Compatible
	HTAA	A modified calcium sulphate product with inert mineral fillers	-268°C to 482°C (-450°F to 900°F)	For use on LOX or LN2 systems
4 Protective Coating Options	PC® 700K System	PC® 80M Mortar and PC® 150 Mesh		
5 Protective Jacketing	PITWRAP® CF Jacketing	Cellulose free fiberglass reinforced vapor retarding jacket	-40°C to 104°C (-40°F to 220°F)	Often supplied pre-jacketed for ease of installation
Other	Metal Cladding Filament Tape Stainless Steel Bands			

¹Service temperature limits are derived from laboratory evaluation of the product. Variations in substrates, loading conditions, or other external factors may further limit service temperature. Always consult Pittsburgh Corning's FOAMGLAS® insulation guide specification for suitability for use recommendations for a specific application.

TANK ROOF/SIDE WALL SYSTEMS

For use with Reinforcing Fabric and Protective Coating or Protective Jacketing

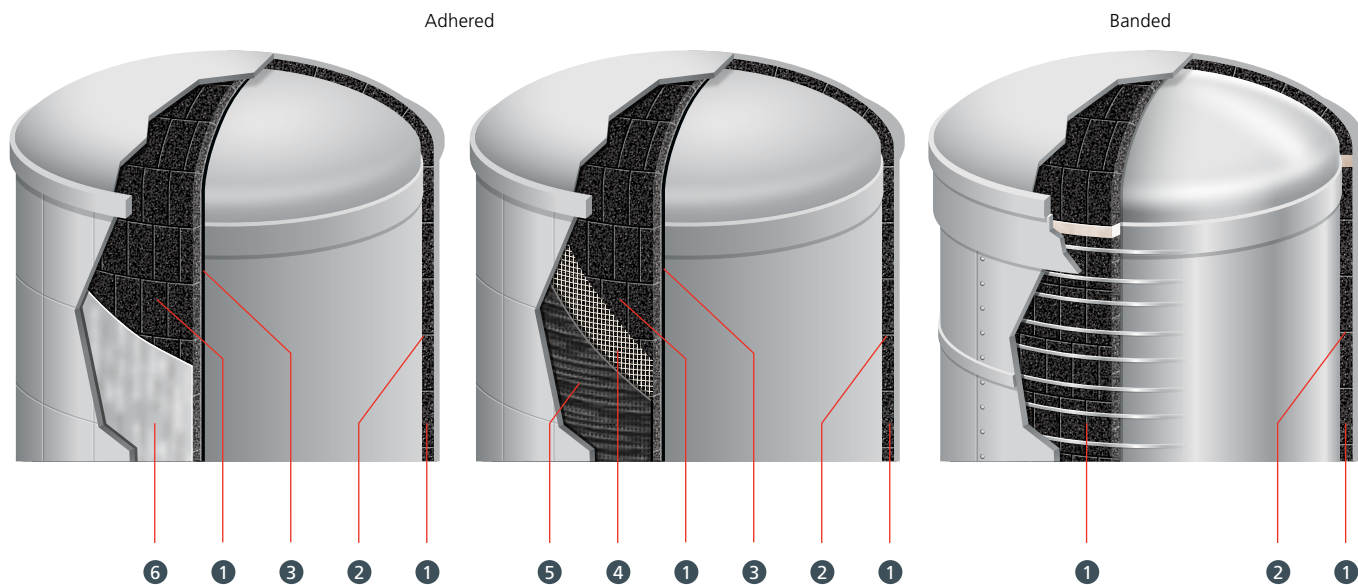

- ① Insulation
- ③ Adhesive
- ⑤ Protective Coating
- ② Joint Sealant
- ④ Reinforcing Fabric
- ⑥ Protective Jacketing

Item	Product Name	Product Description	Service Temperature ¹	Supplemental Information
1 Insulation	FOAMGLAS® Insulation	A lightweight, rigid, cellular glass insulation	-268°C to 482°C (-450°F to 900°F)	
2 Sealant Options	PITTSEAL® 444Ns Sealant	Butyl sealant	-150°C to 82°C (-238°F to 180°F)	For joints, protrusions and laps
	PITTSEAL® 444N Sealant	Butyl sealant	-56.6°C to 82°C (-70°F to 180°F)	For joints, protrusions and laps
3 Adhesive Options	PC® 88 adhesive	Urethane modified Asphalt Adhesive	-180°C to 82°C (-292°F to 180°F)	
	PC® 99 2K adhesive	Two-part adhesive is moisture curing, polyether adhesive sealant	-125°C to 60°C (-193°F to 140°F)	
4 Reinforcing Fabric Options	PC® Fabric 79	Open mesh synthetic fabric	No limit listed	
	PC® 150 Mesh	Open mesh glass fabric	No limit listed	
5 Protective Coating Options	PITTCOTE® 300E Finish	Vapor barrier mastic/coating	-40°C to 93°C (-40°F to 200°F)	Must be protected from UV exposure with metal or other jacketing.
	PITTCOTE® 404 Coating	Weather barrier mastic/coating	-34°C to 82°C (-30°F to 180°F)	
6 Protective Jacketing	PITTWRAF® B100 Jacketing	Self-sealing aluminum butyl laminate for above ground systems	-50°C to 140°C (-58°F to 284°F)	
Other	Metal Jacket Metal Cladding Metal Bands Mineral Wool			

¹Service temperature limits are derived from laboratory evaluation of the product. Variations in substrates, loading conditions, or other external factors may further limit service temperature. Always consult Pittsburgh Corning's FOAMGLAS® insulation guide specification for suitability for use recommendations for a specific application.

CRYOGENIC TANK BASE SYSTEMS

- 1 Insulation
- 2 Adhesive
- 3 Tank Base Primer
- 4 Interleaving Layer
- 5 Jointing Tape

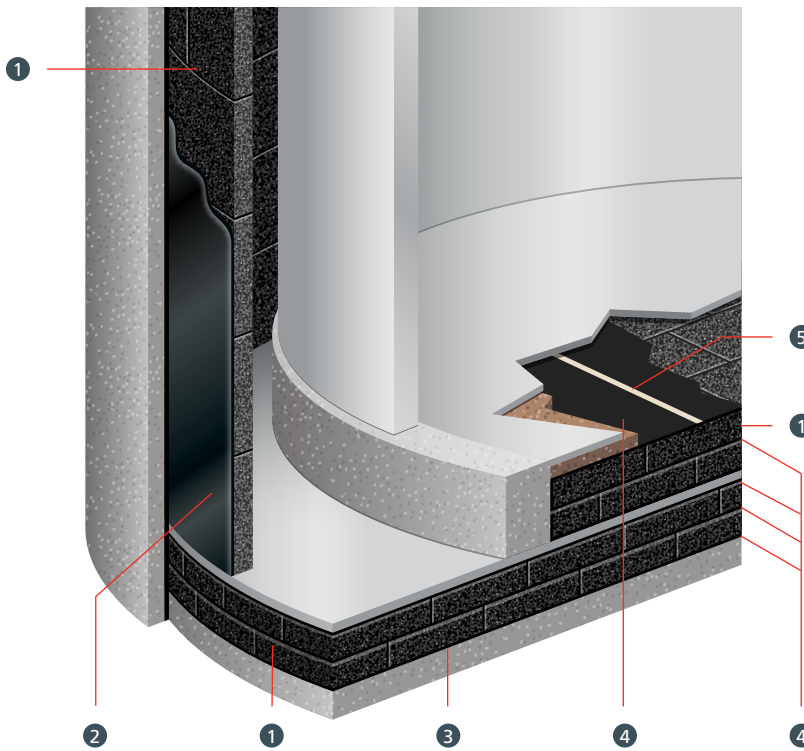

Item	Product Name	Product Description	Service Temperature ¹	Supplemental Information	
1	Insulation	FOAMGLAS® Block Insulation	A high compressive strength and low thermal conductivity cellular glass block specially made for tank base construction and other industrial load bearing applications	Without Load -268°C to 482°C (-450°F to 900°F) With Load -268°C to 400°C (-450°F to 752°F)	Use FOAMGLAS® ONE™ Insulation for sidewalls and FOAMGLAS® HLB Insulation for tank base
2	Adhesive	PC® 88	Urethane modified asphalt adhesive	-150°C to 82°C (-230°F to 180°F)	
		PC® 99 2K	Two part moisture curing, polyether adhesive	-125°C to 60C (-193°F to 140°F)	
3	Tank Base Primer	PITTCOTE® TB Primer	A low VOC cutback asphalt primer used to prime porous and prepared surfaces	-178°C to 82°C (-289°F to 180°F)	
4	Interleaving Layer	PITTCOURSE™ 100 High Performance Damp Proof Course	A modified bitumen, nonmetallic sheet for use between layers of FOAMGLAS® Insulation tank base systems	-180°C to 65°C (-292°F to 149°F)	For use between layers of FOAMGLAS® Insulation
5	Jointing Tape	PITTCOURSE™ DPC Jointing Tape	A modified acrylic double-sided self-adhesive tape, scrim reinforced and solvent free	-180°C to 65°C (-292°F to 149°F)	
Other		Asphalt Saturated Felt Asphalt Base Sheet Ceramic Paper, Sand Resilient Blanket, Perlite			

¹Service temperature limits are derived from laboratory evaluation of the product. Variations in substrates, loading conditions, or other external factors may further limit service temperature. Always consult Pittsburgh Corning's FOAMGLAS® insulation guide specification for suitability for use recommendations for a specific application. Organic materials are not recommended for service temperature below -183°C (297°F)

SPHERE SYSTEMS

Protective Coating
Vapor Barrier Mastic with Cladding

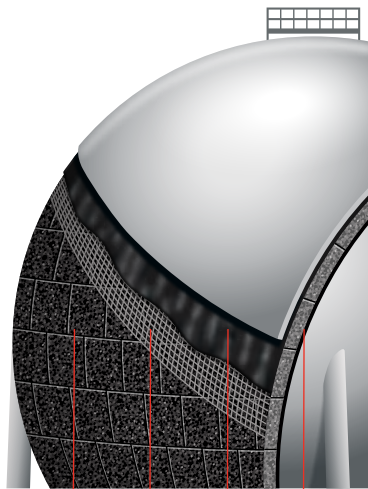

1 3 4 2

Protective Coating
Weather Barrier



1 3 4 2

Protective Jacketing
with Cladding

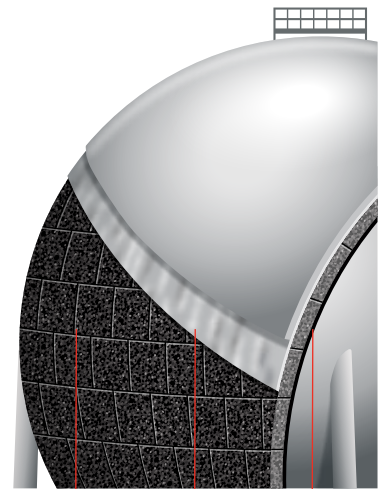

1 5 2

- 1 Insulation
- 2 Adhesive
- 3 Reinforcing Fabric
- 4 Protective Coating
- 5 Protective Jacketing

Item	Product Name	Product Description	Service Temperature ¹	Supplemental Information
1 Insulation	FOAMGLAS® Insulation	A lightweight, rigid, cellular glass insulation	-268°C to 482°C (-450°F to 900°F)	
2 Adhesive Options	PC® 88 adhesive	Urethane modified asphalt adhesive	-178°C to 82°C (-289°F to 180°F)	
	PC® 99 2K adhesive	Two-part adhesive is moisture curing, polyether adhesive sealant	-125°C to 60°C (-193°F to 140°F)	
3 Reinforcing Fabric Options	PC® Fabric 79	Open mesh synthetic fabric	No limit listed	
	PC® 150 Mesh	Open mesh glass fabric	No limit listed	
4 Protective Coating Options	PITTCOTE® 300E Finish	Vapor barrier mastic/coating	-40°C to 93°C (-40°F to 200°F)	Must be protected from UV exposure with metal or other jacketing.
	PITTCOTE® 404 Coating	Weather barrier mastic/coating	-34°C to 82°C (-30°F to 180°F)	
5 Protective Jacketing	PITWRAP® B100 Jacketing	Self-sealing aluminum butyl laminate	-50°C to 140°C (-58°F to 284°F)	
6 Other	Metal Bands Metal Cladding Elastomeric Sealant			

¹Service temperature limits are derived from laboratory evaluation of the product. Variations in substrates, loading conditions, or other external factors may further limit service temperature. Always consult Pittsburgh Corning's FOAMGLAS® insulation guide specification for suitability for use recommendations for a specific application.

DISCOVER OUR FULL LINE OF FOAMGLAS® INSULATION SYSTEMS ACCESSORIES

PITTCOTE® COATINGS

Our exterior coatings provide protection from weather, ultraviolet rays, and mechanical damage.



PC® ADHESIVES

Pittsburgh Corning adhesives are available for a wide range of FOAMGLAS® insulation applications on a variety of different substrates.



PITTWRAP® JACKETINGS

PITTWRAP® Jacketings protect FOAMGLAS® insulation systems from physical and mechanical damage and shields the insulation from the elements.

PITTCOURSE™ TANK BASE SYSTEMS

PITTCOURSE™ High performance DPC and the tank base accessory products are used in conjunction with FOAMGLAS® HLB Insulation on cold and cryogenic tank bases.

PITTSEAL® SEALANTS AND PITSTOP™ PRODUCTS

When used at joints, laps, protrusions and vapor stops, these products control water vapor migration.



FOAMGLAS®

Pittsburgh Corning

©2017. Pittsburgh Corning. FOAMGLAS®, PITTSEAL®, PITTCOTE®, PITTWRAP® and PC® are federally registered trademarks in the United States and various other countries.

Disclaimer: The information contained herein is accurate and reliable to the best of our knowledge. The information is offered only as a guide for the purpose described herein and should be employed at the discretion of the user. This document has been prepared by Pittsburgh Corning using generally accepted and appropriate technical information, but it is not intended to be solely relied upon for specific design or technical applications. Having no control over the elements of design, installation, workmanship or site conditions, the final application procedure is the responsibility of the project designer, end user, and/or the owner. Therefore, Pittsburgh Corning disclaims all liability potentially arising from the use or misuse of this document, and NO EXPRESS OR IMPLIED WARRANTY OF ANY KIND, INCLUDING THOSE OF MERCHANTABILITY OR FITNESS FOR A PARTICULAR PURPOSE, IS MADE as to the performance of an installation containing Pittsburgh Corning products. In no event shall Pittsburgh Corning be liable for any damages arising because of product failure, whether incidental, special, consequential or punitive, regardless of the theory of liability upon which any such damages are claimed. Pittsburgh Corning provides written warranties for many of its products, and such warranties take precedence over the statements contained here.